



# 1969-70 Ford Mustang

*without* Factory Air  
Evaporator Kit  
(551170)



18865 Goll St. San Antonio, TX 78266  
Phone: 800-862-6658  
Sales: [sales@vintageair.com](mailto:sales@vintageair.com)  
Tech Support: [tech@vintageair.com](mailto:tech@vintageair.com)  
[www.vintageair.com](http://www.vintageair.com)



www.vintageair.com

# Table of Contents

|  |    |
|--|----|
| Cover.....   | 1  |
| Table of Contents.....   | 2  |
| Packing List/Parts Disclaimer.....   | 3  |
| Information Page.....  | 4  |
| Wiring Notice.....   | 5  |
| Engine Compartment Disassembly, Condenser Assembly and Installation, Compressor and Brackets, Passenger Compartment Disassembly..... | 6  |
| Defrost Duct Installation, Fresh Air Cap Installation, Driver and Passenger Side Louver Installation.....                            | 7  |
| Evaporator Installation.....   | 8  |
| Firewall Cover Installation.....   | 9  |
| Center Louver Installation (Option 1), Center Louver Installation (Option 2) .....   | 10 |
| Drain Hose Installation, Lubricating O-rings, A/C Hose Installation.....   | 11 |
| Heater Hose & Heater Control Valve Installation.....   | 12 |
| A/C and Heater Hose Routing.....   | 13 |
| Final Steps, Glove Box Installation.....   | 14 |
| Duct Hose Routing.....   | 15 |
| Evaporator Hardline Installation.....  | 16 |
| Wiring Diagram.....  | 17 |
| Gen IV Wiring Connection Instruction.....  | 18 |
| Operation of Controls.....   | 19 |
| Troubleshooting Guide.....   | 20 |
| Troubleshooting Guide (Cont.).....   | 21 |
| Driver Side Louver Template.....   | 22 |
| Passenger Side Louver Template.....  | 23 |
| Center Louver Template.....  | 24 |
| Firewall Cover Hole Template.....  | 25 |
| Packing List.....  | 26 |



www.vintageair.com

## Packing List: Evaporator Kit (551170)

| No. | Qty. | Part No.   | Description                       |
|-----|------|------------|-----------------------------------|
| 1.  | 1    | 744004-VUE | Gen IV 4-Vent Evaporator Sub Case |
| 2.  | 1    | 781069     | Accessory Kit                     |

**\*\* Before beginning installation, open all packages and check contents of shipment. Please report any shortages directly to Vintage Air within 15 days. After 15 days, Vintage Air will not be responsible for missing or damaged items.**

1

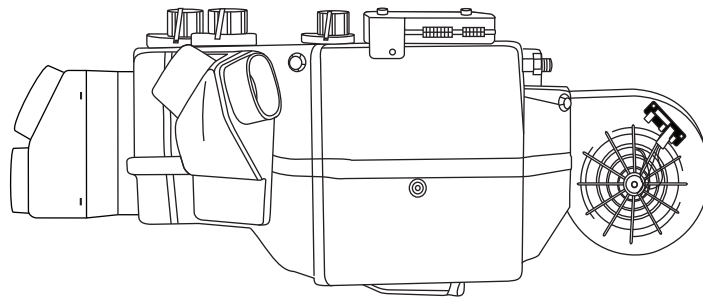

**Gen IV 4-Vent Evaporator  
Sub Case  
744004-VUE**

2

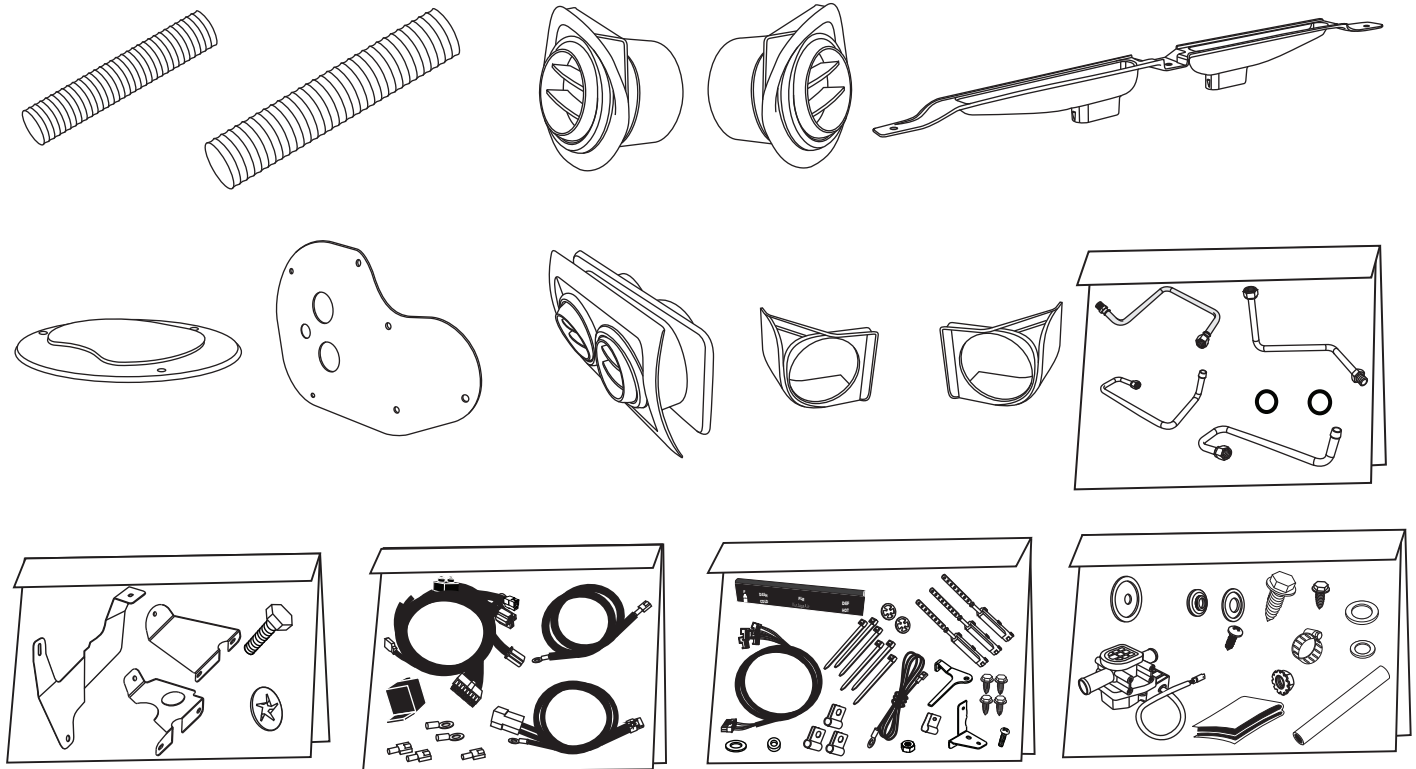

**Accessory Kit  
781069**

**NOTE: Images may not depict actual parts and quantities. Refer to packing list for actual parts and quantities.**



www.vintageair.com

## Important Notice—Please Read

*For Maximum System Performance, Vintage Air Recommends the Following:*

**NOTE:** Vintage Air systems are designed to operate with R134a refrigerant only. Use of any other refrigerant could damage your A/C system and/or vehicle, and possibly cause a fire, in addition to potentially voiding the warranties of the A/C system and its components.

### Refrigerant Capacities:

**Vintage Air System:** 1.8 lbs. (28.8 oz.) or 816 grams of **R134a**, charged by weight with a quality charging station or scale. **NOTE: Use of the proper type and amount of refrigerant is critical to system operation and performance.**

**Other Systems:** Consult manufacturer's guidelines.

### Lubricant Capacities:

**New Vintage Air-Supplied Sanden Compressor:** No additional oil needed (Compressor is shipped with proper oil charge).

**All Other Compressors:** Consult manufacturer (Some compressors are shipped dry and will need oil added).

### Safety Switches

Your Vintage Air system is equipped with a binary pressure safety switch. A binary switch disengages the compressor clutch in cases of extreme low pressure conditions (refrigerant loss) or excessively high head pressure (406 PSI) to prevent compressor damage or hose rupture. A trinary switch combines Hi/Lo pressure protection with an electric fan operation signal at 254 PSI, and should be substituted for use with electric fans. Compressor safety switches are extremely important since an A/C system relies on refrigerant to circulate lubricant.

### Service Info:

**Protect Your Investment:** Prior to assembly, it is critical that the compressor, evaporator, A/C hoses and fittings, hardlines, condenser and receiver/drier remain capped. Removing caps prior to assembly will allow moisture, insects and debris into the components, possibly leading to reduced performance and/or premature failure of your A/C system. This is especially important with the receiver/drier.

Additionally, when caps are removed for assembly, **BE CAREFUL!** Some components are shipped under pressure with dry nitrogen.

**Evacuate the System for 35-45 Minutes:** Ensure that system components (Drier, compressor, evaporator and condenser) are at a temperature of at least 85°F. On a cool day, the components can be heated with a heat gun **or** by running the engine with the heater on before evacuating. Leak check and charge to specifications.

### Bolts Passing Through Cowl and/or Firewall:

To ensure a watertight seal between the passenger compartment and the vehicle exterior, for all bolts passing through the cowl and/or firewall, Vintage Air recommends coating the threads with silicone prior to installation.

### Heater Hose (not included with this kit):

Heater hose may be purchased from Vintage Air (Part#31800-VUD) or your local parts retailer. Routing and required length will vary based on installer preference.



www.vintageair.com

## Important Wiring Notice—Please Read

*Some vehicles may have had some or all of their radio interference capacitors removed. There should be a capacitor found at each of the following locations:*

- 1. On the positive terminal of the ignition coil.**
- 2. If there is a generator, on the armature terminal of the generator.**
- 3. If there is a generator, on the battery terminal of the voltage regulator.**

Most alternators have a capacitor installed internally to eliminate what is called “whining” as the engine is revved. If whining is heard in the radio, or just to be extra cautious, a radio interference capacitor can be added to the battery terminal of the alternator.

It is also important that the battery lead is in good shape and that the ground leads are not compromised. There should be a heavy ground from the battery to the engine block, and additional grounds to the body and chassis.

If these precautions are not observed, it is possible for voltage spikes to be present on the battery leads. These spikes come from ignition systems and charging systems, and from switching some of the vehicle’s other systems on and off. Modern computer-operated equipment can be sensitive to voltage spikes on the power leads, which can cause unexpected resets, strange behavior and/or permanent damage.

Vintage Air strives to harden our products against these types of electrical noise, but there is a point where a vehicle’s electrical system can be degraded so much that nothing can help.

Radio interference capacitors should be available at most auto and truck parts suppliers. They typically are cylindrical in shape, a little over an inch long and a little over a half-inch in diameter, and they have a single lead coming from one end of the cylinder with a terminal on the end of the wire, as well as a mounting clip which is screwed into a good ground on the vehicle. The specific value of the capacitance is not too significant in comparison to ignition capacitors that are matched with the coil to reduce pitting of the points.

- Care must be taken, when installing the compressor lead, not to short it to ground. The compressor lead must not be connected to a condenser fan or to any other auxiliary device. Shorting to ground or connecting to a condenser fan or any other auxiliary device may damage wiring or the compressor relay, and/or cause a malfunction.
- When installing ground leads on Gen IV systems, the blower control ground and ECU ground must be connected directly to the negative battery post.
- For proper system operation, the heater control valve must be connected to the ECU.



www.vintageair.com

## Engine Compartment Disassembly

**NOTE:** Before starting the installation, check the function of the vehicle (horn, lights, etc.) for proper operation, and study the instructions, illustrations, & diagrams.

**Perform the Following:**

1. Disconnect the battery.
2. Remove the battery and battery tray (retain).
3. Drain the radiator.
4. Remove the OEM heater hoses (discard).

## Condenser Assembly and Installation

1. Refer to separate instructions included with the condenser kit to install the condenser.
2. Binary switch installation (Refer to condenser instructions).

## Compressor and Brackets

1. Refer to separate instructions included with the bracket kit to install the compressor bracket.

## Passenger Compartment Disassembly

**NOTE:** Removal of the dashboard is required to install the evaporator. Vintage Air recommends that you utilize the factory service manual when disassembling and reassembling the dashboard.

**Perform the Following:**

1. Remove the dash pad, instrument panel, passenger side panel and lower passenger side dashboard (retain screws) (See Figure 1, below).
2. Remove the glove box (discard) (See Figure 1, below). **NOTE: The glove box will not fit with the evaporator unit installed. A with factory air vehicle aftermarket glove box will need to be purchased.**
3. Remove the heater assembly and all related ducting (discard) (retain screws) (See Figure 2, below). Remove the control panel assembly (retain control panel) (See Figure 1, below). **NOTE: Refer to the control panel conversion kit instructions for installation of the controls.**
4. Remove the OEM defrost duct assembly (See Figure 2, below).

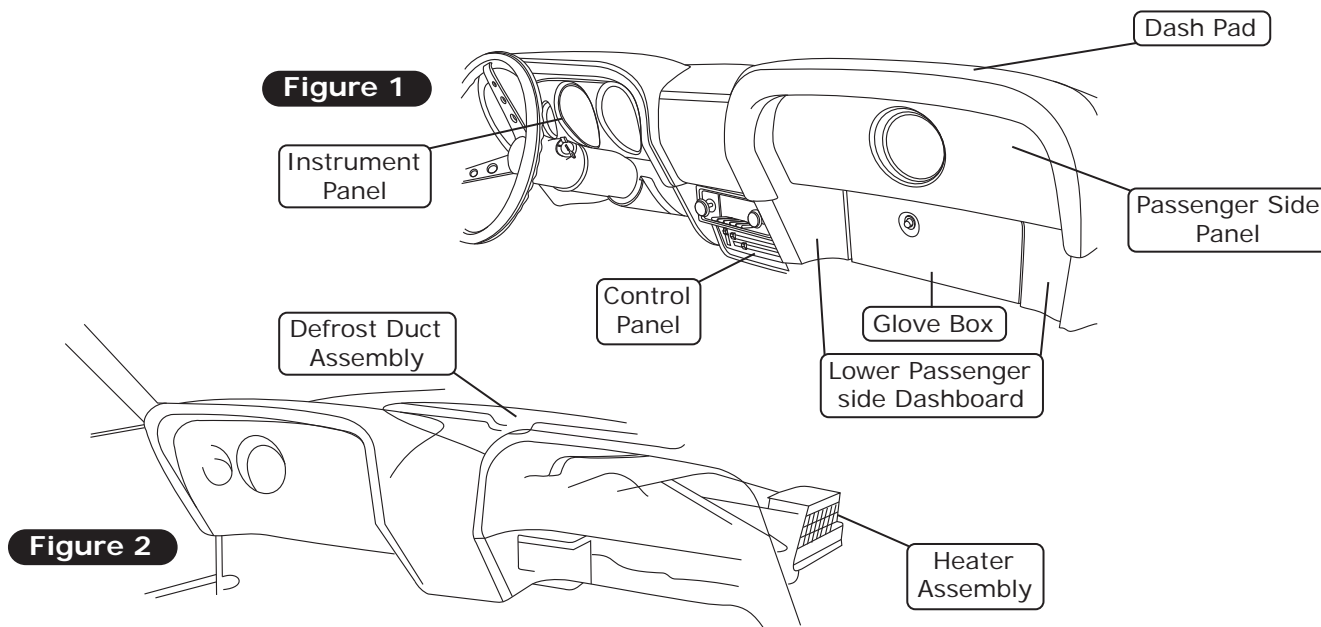



www.vintageair.com

## Defrost Duct and Fresh Air Cap Installation

1. Install the defrost duct under the dash as shown in Figure 3, below. Secure it using the OEM nuts with (3) 3/16" flat washers.
2. Hold the fresh air cap under the dash and mark the (3) mounting holes.
3. Drill (3) 1/8" mounting holes under the dash.
4. Apply a 1/4" bead of silicone around the back side of the fresh air cap as shown in Figure 3, below.
5. Secure the fresh air cap to the fresh air hole using (3) #10 x 1/2" sheet metal screws as shown in Figure 3, below.

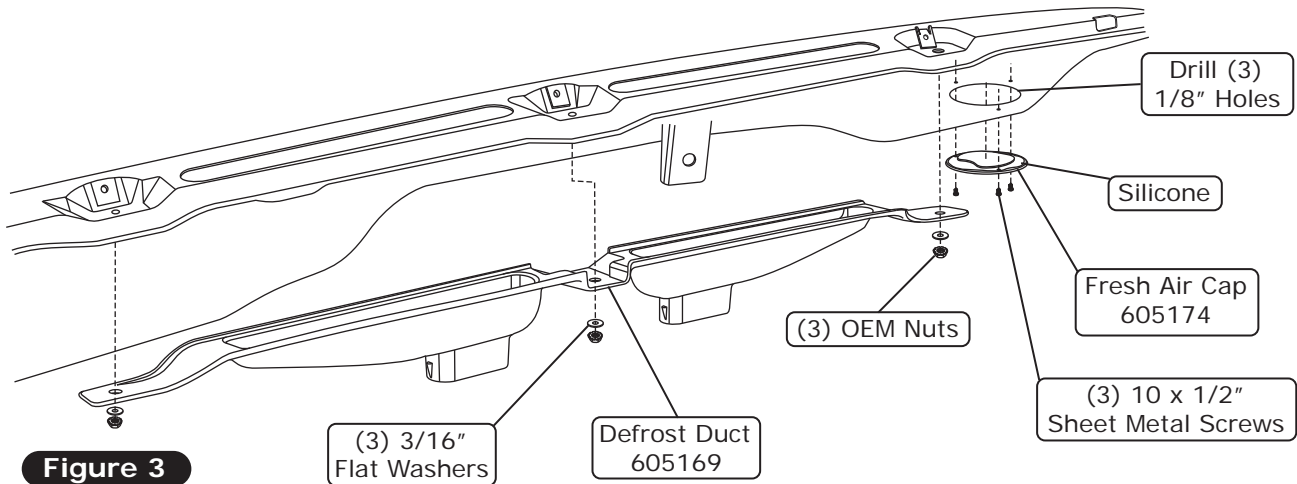

## Driver and Passenger Side Louver Installation

1. Cut out the template provided on Page 22. Place the driver side template on the dash by aligning the left side of the template against the edge of the dash, then align the bottom of the template to the bottom of the dash as shown in Figure 4, below.
2. Cut out the template provided on Page 23. Place the passenger side template on the dash by aligning the right side of the template against the edge of the dash, then align the bottom of the template to the bottom of the dash as shown in Figure 4, below.
3. Once the template is aligned correctly, use a center punch to mark the hole on the dash. Remove the template. Use a 2 3/4" hole saw to cut a hole in the dash (See Figure 4, below).
4. Install the louvers in the dash as shown in Figure 4a, below.

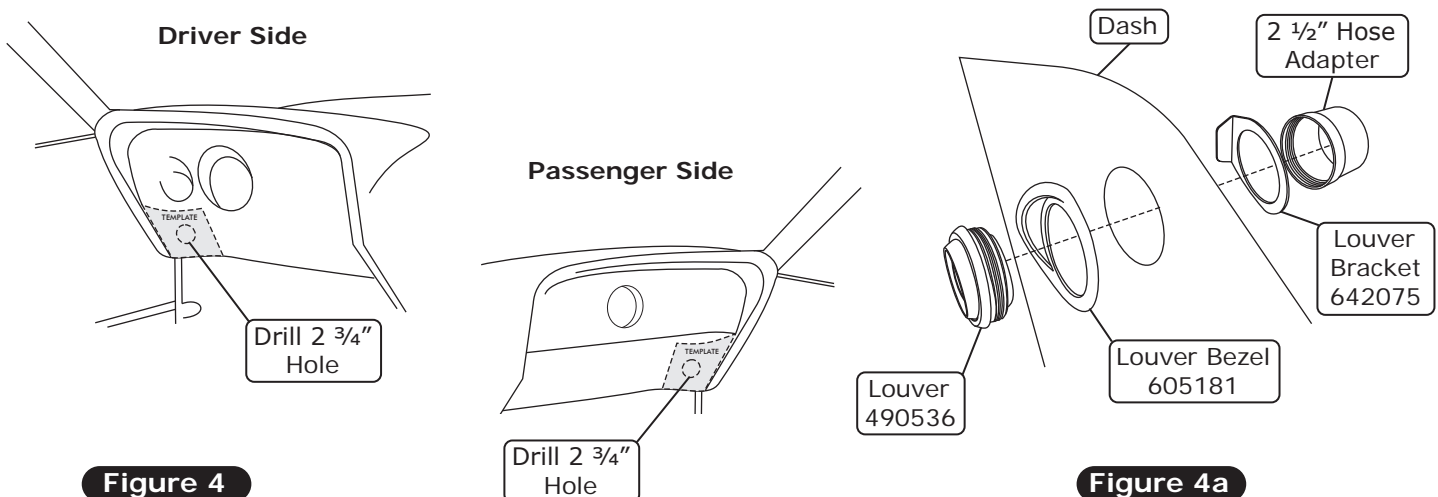



www.vintageair.com

## Evaporator Installation

1. Use the template provided on Page 25. Align the template with the OEM blower motor mounting holes and drill (6) 3/16" holes in the firewall from inside the passenger compartment and under the dash (See Figure 5a, below).
2. On a work bench, install the evaporator rear bracket and hardlines with properly lubricated O-rings (See Figure 10, Page 12 and Figure 15, Page 16).
3. Remove the (2) OEM heater plugs in the firewall (See Figure 7, Page 9).
4. Install the front mounting bracket onto the evaporator using (2) 1/4-20 x 1/2" hex bolts (supplied on the sub case) and tighten as shown in Figure 5, below.
5. Lift the evaporator unit up under the dashboard (See Figure 6, below). Secure it loosely to the firewall from the engine compartment side using (2) 1/4-20 nuts and (2) 1/4" washers (See Figure 6, below).
6. Using (2) #14 x 3/4" sheet metal screws with 1/4" flat washers, secure the front evaporator mounting bracket to the inner cowl (See Figure 6, below).
7. Verify that the evaporator unit is level and square to the dash, then tighten all mounting bolts. **NOTE: Tighten the bolt on the firewall first, then the front mounting bracket screws.**

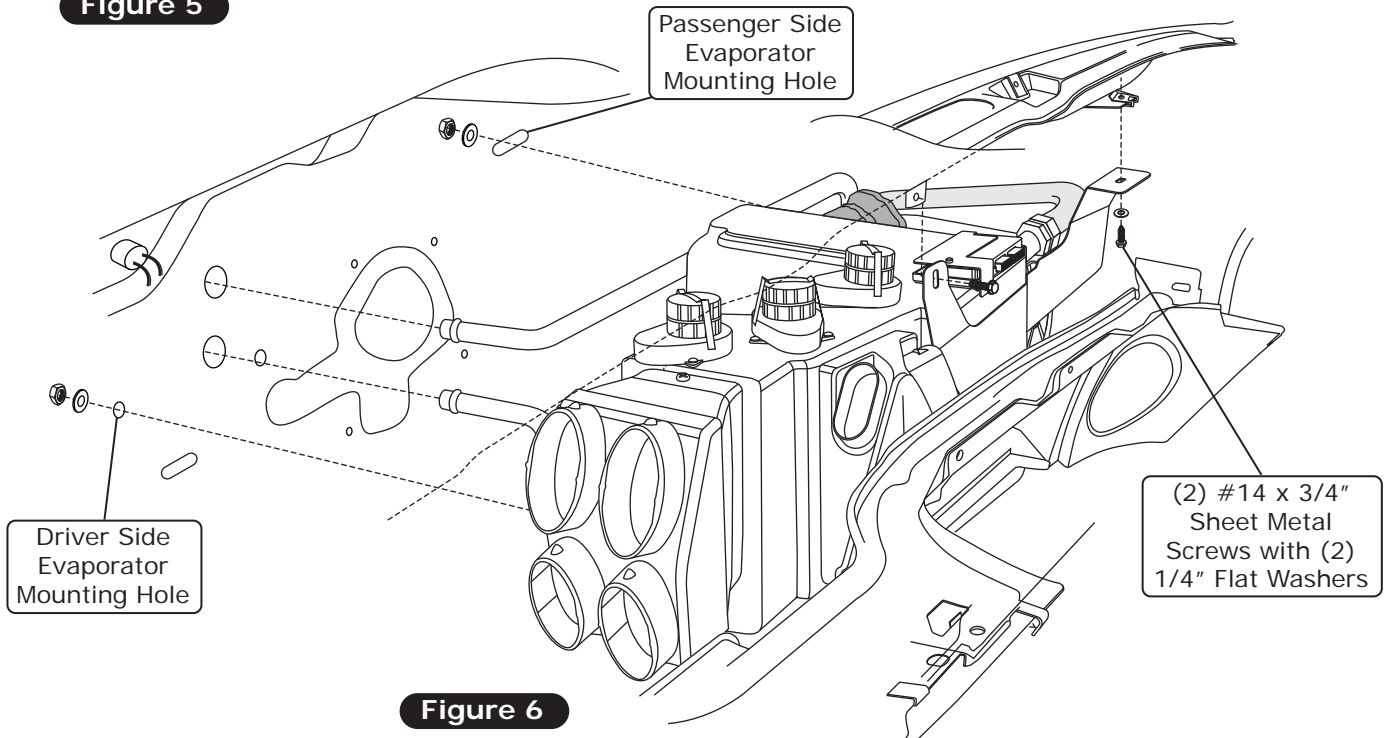
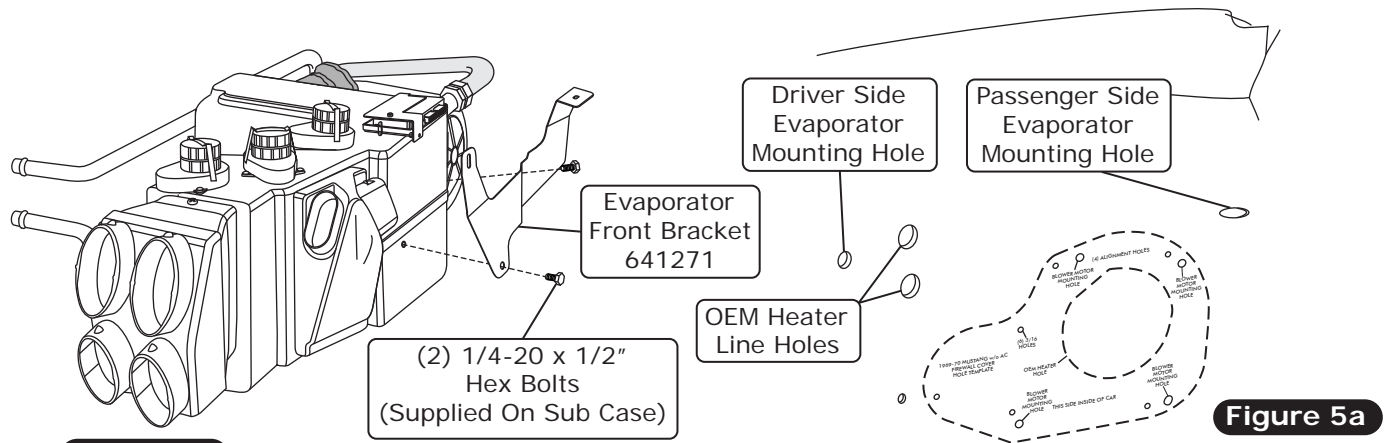





www.vintageair.com

## Firewall Cover Installation

1. Install (3) grommets onto the firewall cover as shown in Figure 7, below.
2. Apply a 1/4" bead of silicone around the back side of the firewall cover as shown in Figure 7a, below.
3. Secure the firewall cover to the firewall using (6) #14 x 3/4" sheet metal screws (See Figure 7, below).

**NOTE: The firewall cover installs on the engine side of firewall.**

Back Side of Firewall Cover

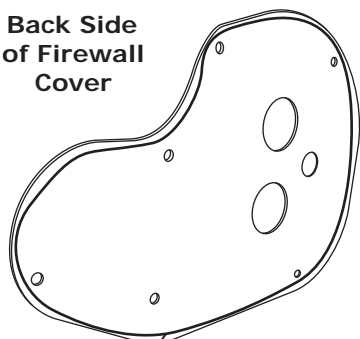

Figure 7a

Silicone

Engine Compartment Side of Firewall Cover

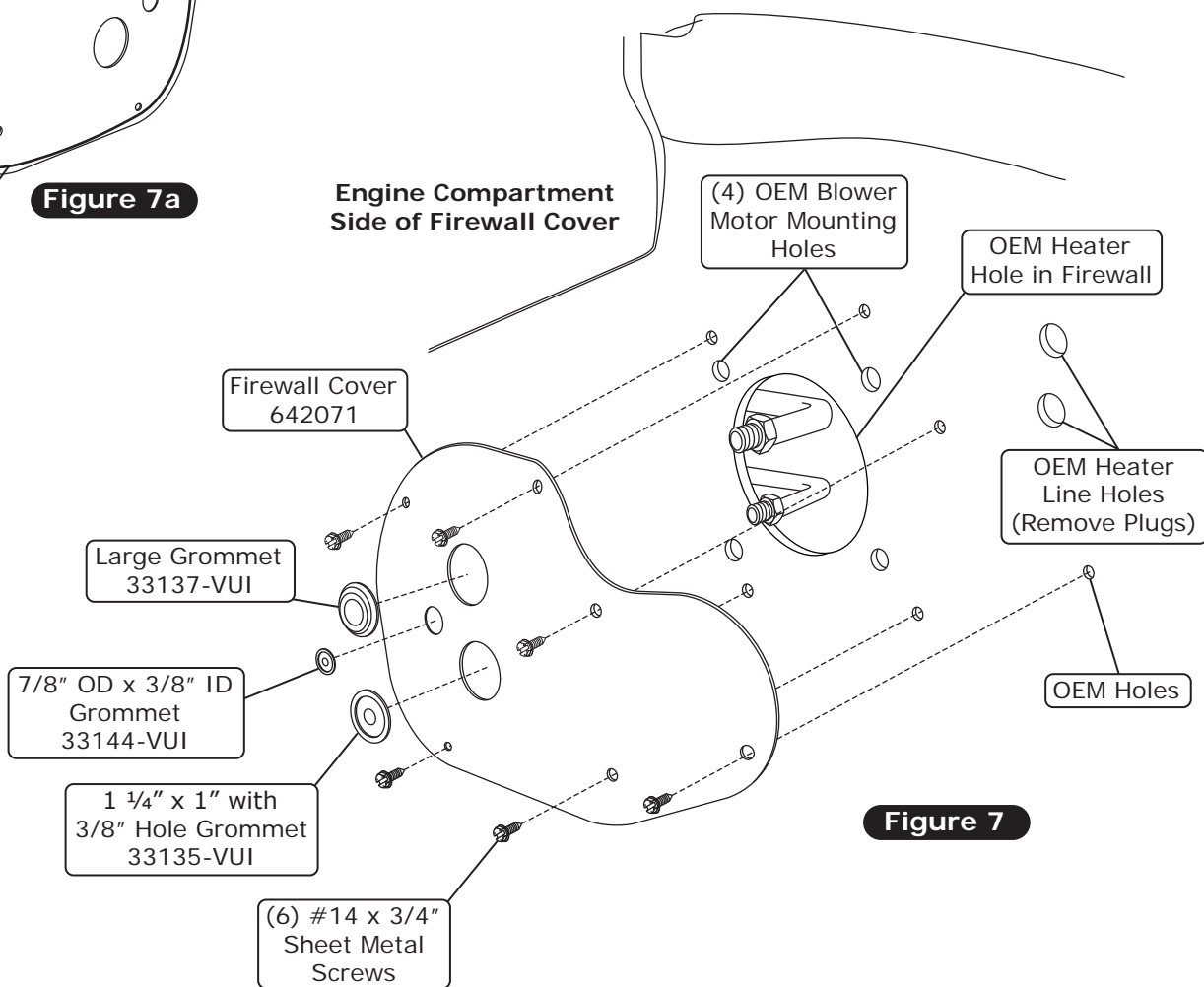

Figure 7



www.vintageair.com

## Center Louver Installation (Option 1)

1. Cut out the center louver template provided on Page 24. Align the center louver template onto the dash pad as shown in Figure 8a, below.
2. Mark the center louver opening onto the dash pad. Once the center louver opening is marked, remove the template and carefully cut out the opening in the dash pad.
3. Install the center louver assembly as shown in Figure 8, below.

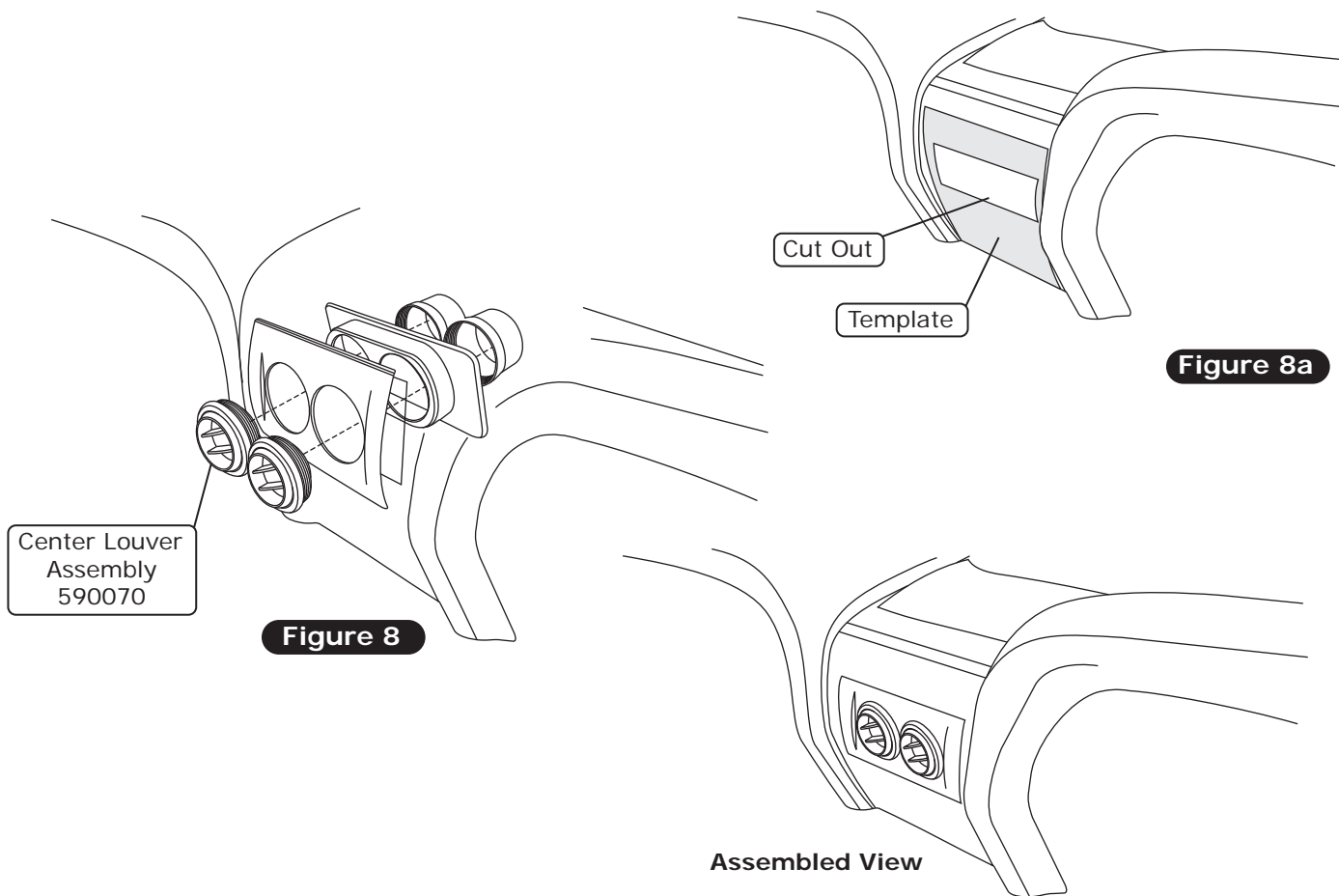

## Center Louver Installation (Option 2)

1. Install the under dash louvers using (3) #8 x 1/2" pan head screws.

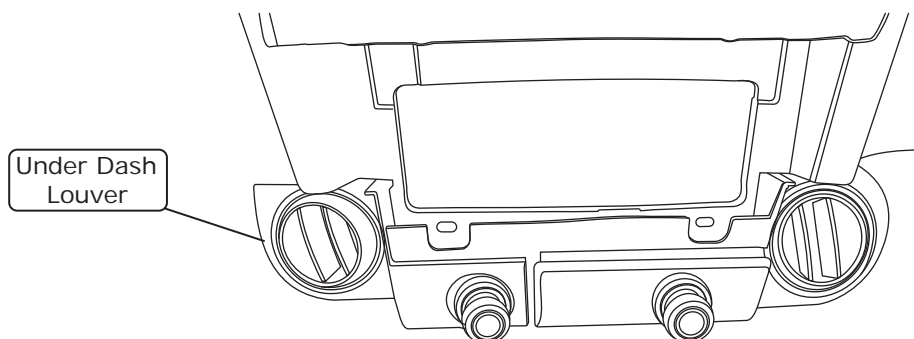



www.vintageair.com

## Drain Hose Installation

1. Locate the evaporator drain on the bottom of the evaporator case.
2. In-line with the drain, lightly make a mark on the firewall. Measure one inch down and drill a 5/8" hole through the firewall (See Figure 9, below).
3. Install the drain hose onto the bottom of evaporator unit and route it through the firewall (See Figure 9, below).

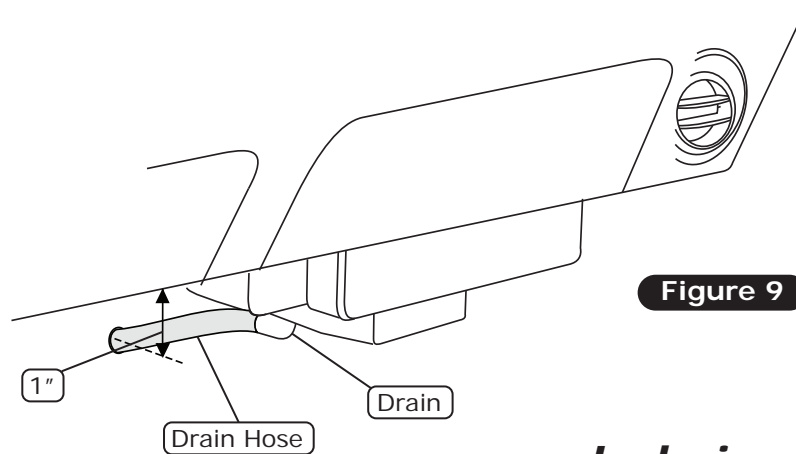
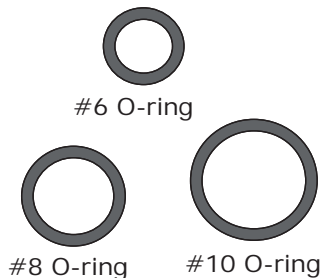
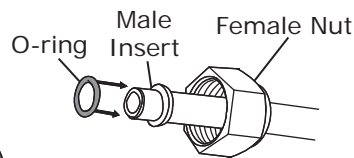

Figure 9

## Lubricating O-rings



**NOTE: Standard torque specifications:**  
 #6: 11 to 13 ft-lb.  
 #8: 15 to 20 ft-lb.  
 #10: 21 to 27 ft-lb.



**For a proper seal of fittings: Install supplied O-rings as shown and lubricate with supplied oil.**

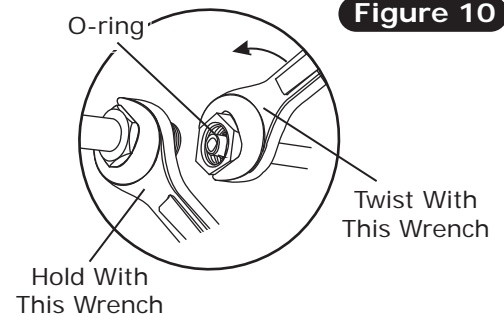
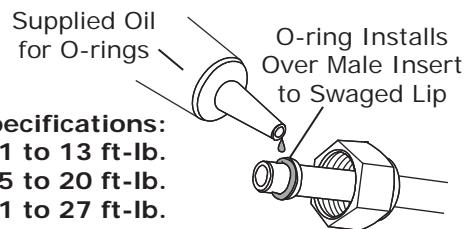

Figure 10

## A/C Hose Installation

### Standard Hose Kit:

1. Locate the #8 compressor A/C hose. Lubricate (2) #8 O-rings (See Figure 10, above) and connect the 45° fitting to the #8 discharge port on the compressor. Then route the straight fitting with service port to the #8 condenser hardline coming through the radiator core support (See Figure 12, Page 13). Tighten each fitting connection as shown in Figure 10, above.
2. Locate the #10 compressor A/C hose. Lubricate (2) #10 O-rings (See Figure 10, above) and connect the 90° with fitting with service port to the #10 suction port on the compressor. Then route the 135° fitting to the #10 evaporator hardline coming through the firewall (See Figure 11, Page 12 & Figure 12, Page 13). Tighten each fitting connection as shown in Figure 10, above. **NOTE: Wrap the #10 fitting connections with press tape (See Figure 11, Page 12 & Figure 12, Page 13).**
3. Locate the #6 evaporator/drier hose. Lubricate (2) #6 O-rings (See Figure 10, above) and connect the straight fitting the #6 drier hardline coming through the radiator core support. Route the 90° fitting to the #6 evaporator hardline coming through the firewall (See Figure 11, Page 12 & Figure 12, Page 13). Tighten each fitting connection as shown in Figure 10, above.

### Modified Hose Kit:

1. Refer to separate instructions included with modified hose kit.



www.vintageair.com

## Heater Hose & Heater Control Valve Installation

1. Route a piece of heater hose from the water pump to the heater line coming through the firewall as shown in Figure 11, below. Secure it using hose clamps.
2. Route a piece of heater hose from the intake to the heater line coming through the firewall as shown in Figure 11, below. **NOTE: Install the heater control valve in-line with the intake manifold (pressure side) heater hose and secure it using hose clamps as shown in Figure 11, below. Note proper flow direction.**

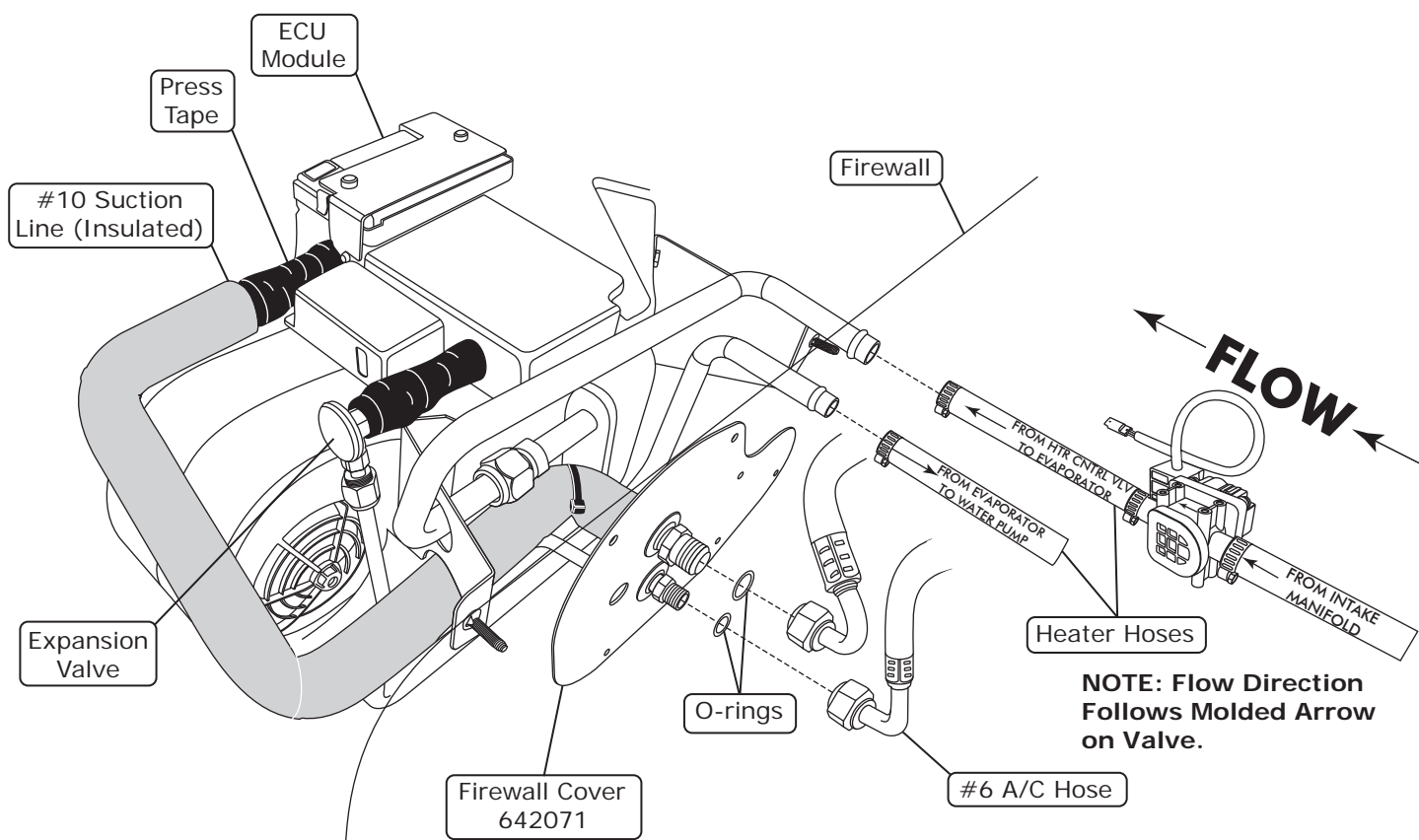

Figure 11



www.vintageair.com

# A/C and Heater Hose Routing

NOTE: Vintage Air Systems use 5/8" heater connections. On engines equipped with 3/4" hose nipples, these will need to be removed and replaced with 5/8" nipples (not supplied). For water pumps with a cast-in 3/4" heater outlet, a 3/4" x 5/8" reducer fitting in the heater hose (not supplied) or molded hose (Vintage Air Part # 099010) will need to be installed.

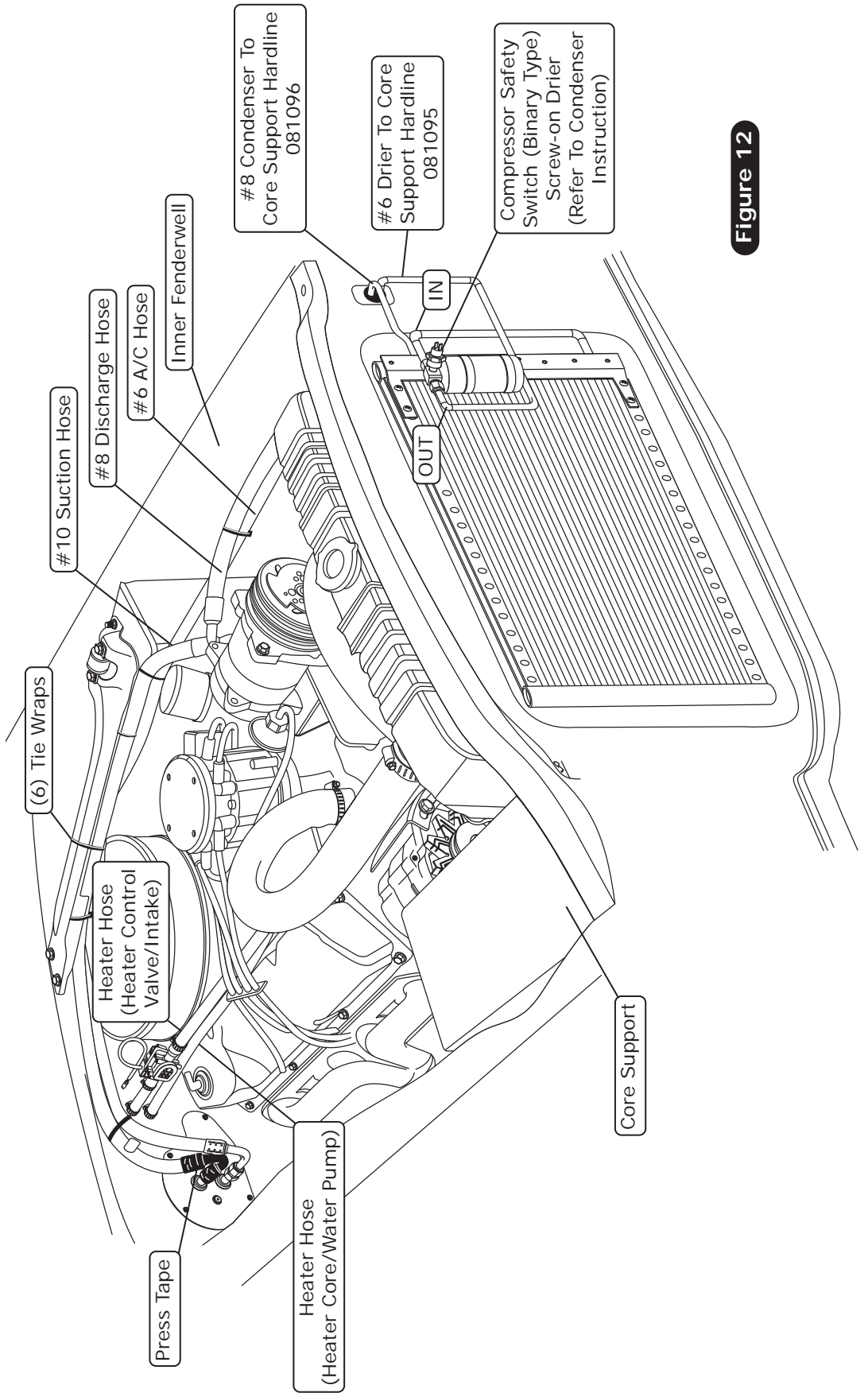

Figure 12



www.vintageair.com

## Final Steps

1. Install the duct hoses as shown in Figure 14, Page 15.
2. Route the A/C wires (12 volt/ground/binary switch/heater valve) through the 3/8" grommet as shown in Figure 13a, below.
3. Install the control panel assembly. Refer to control panel instructions.
4. Plug the wiring harnesses into the ECU module on the sub case as shown in Figure 14, Page 15.  
**NOTE: Install the wire according to the wiring diagrams on Pages 17 and 18.**
5. Install the glove box (See Figure 13, below).
6. Reinstall all previously removed items.
7. Fill radiator with at least a 50/50 mixture of approved antifreeze and distilled water. It is the owner's responsibility to keep the freeze protection at the proper level for the climate in which the vehicle is operated. Failure to follow antifreeze recommendations will cause heater core to corrode prematurely and possibly burst in A/C mode and/or freezing weather, voiding your warranty.
8. Double check all fittings, brackets and belts for tightness.
9. Vintage Air recommends that all A/C systems be serviced by a licensed automotive A/C technician.
10. Evacuate the system for a minimum of 45 minutes prior to charging, and perform a leak check prior to servicing.
11. Charge the system to the capacities stated on Page 4 of this instruction manual.
12. See Operation of Controls procedures on Page 19.

## Glove Box Installation

1. Install the glove box with the OEM screws (See Figure 13, below).

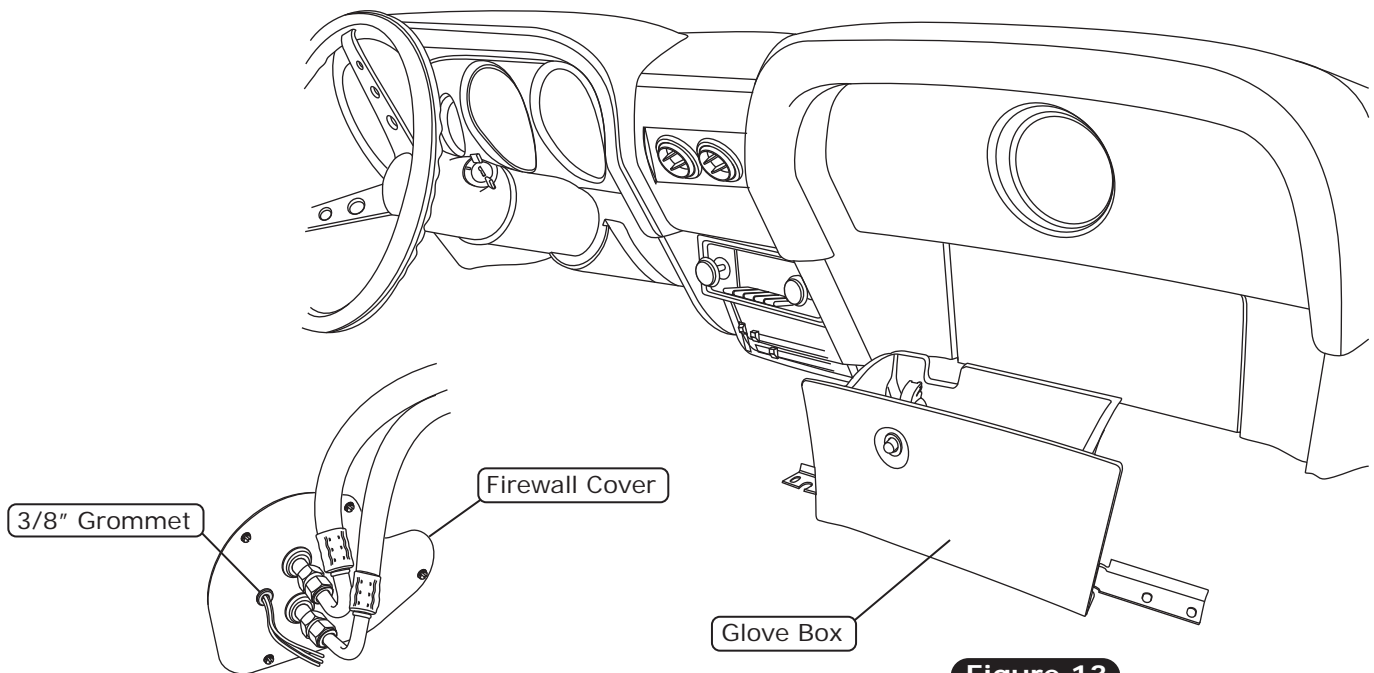

Figure 13a

Figure 13



# Duct Hose Routing

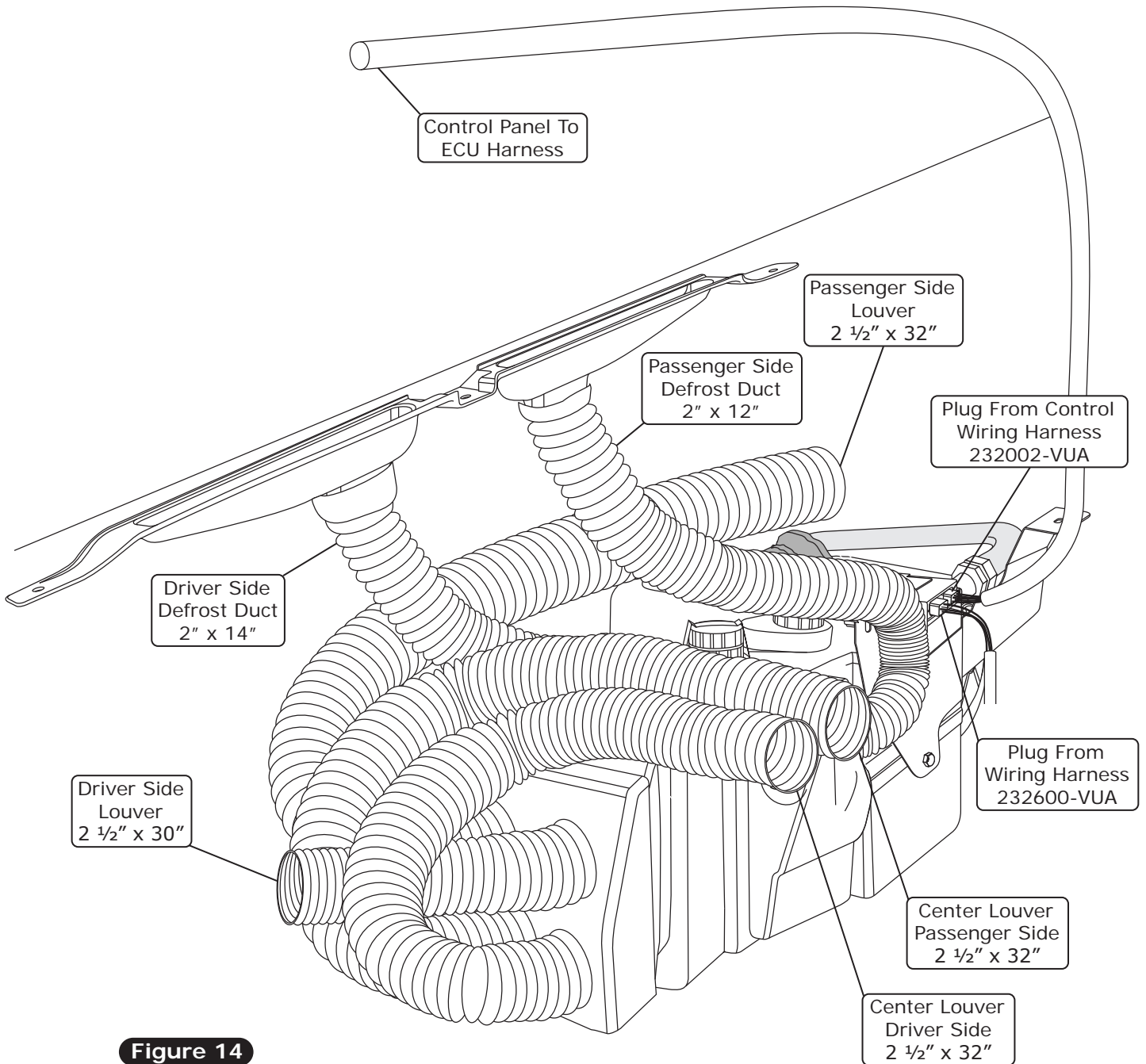

Figure 14



www.vintageair.com

# Evaporator Hardline Installation

**NOTE:** After Installing #10 Suction Line, Wrap All Exposed Metal Fittings & Tubes With Supplied Press Tape.

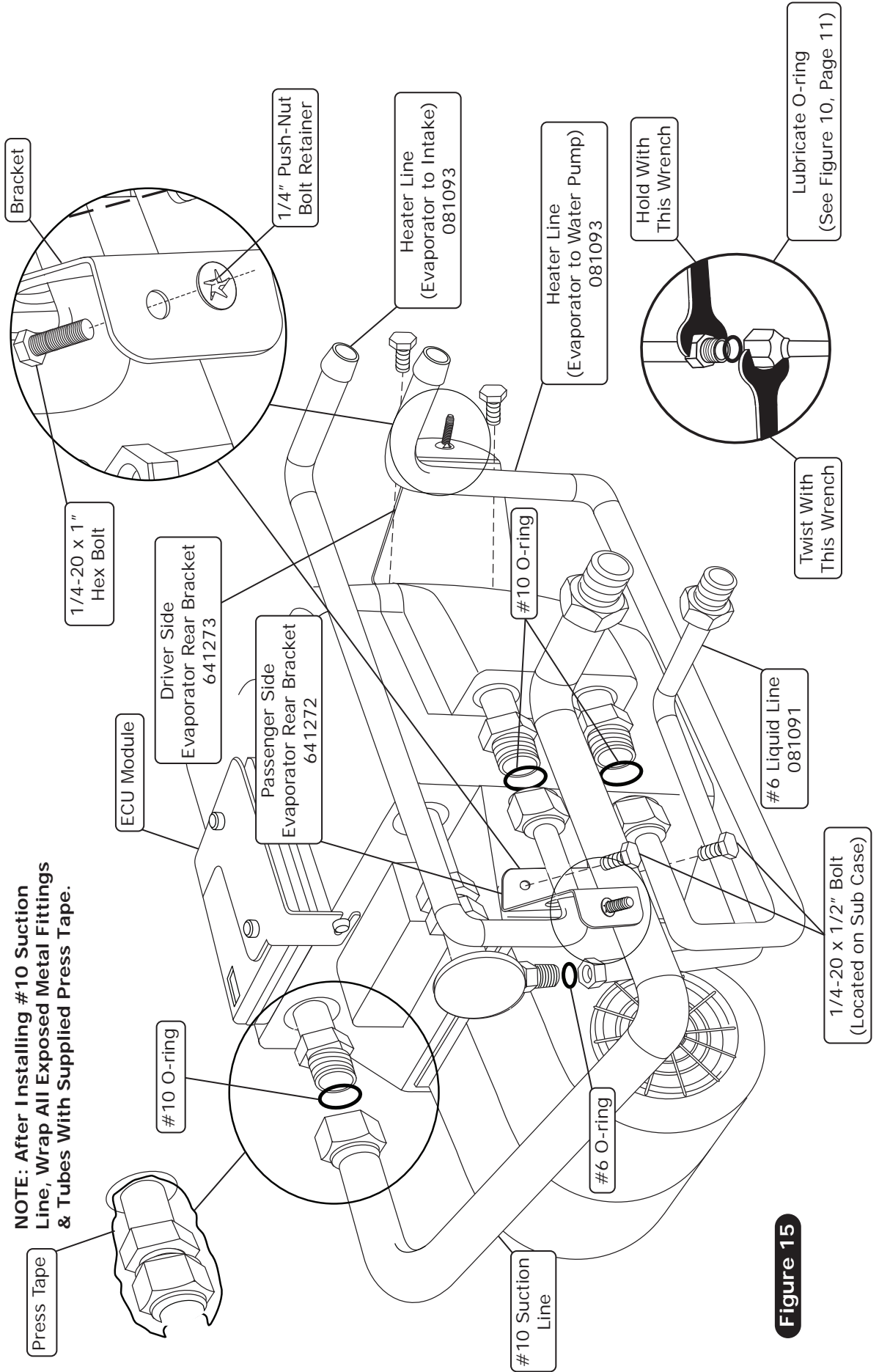

**Figure 15**





www.vintageair.com

# Gen IV Wiring Diagram

232007-VUR

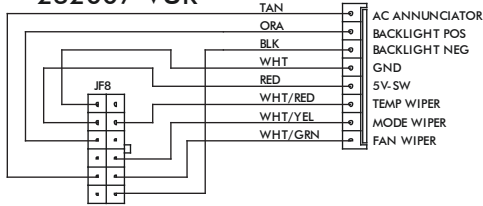

VIEWED FROM WIRE SIDE

232002-VUA

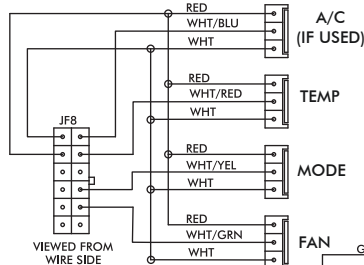

VIEWED FROM WIRE SIDE

PROGRAM

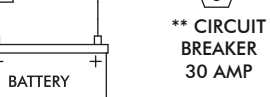
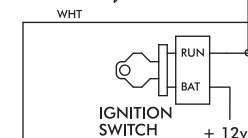

GEN IV ECU

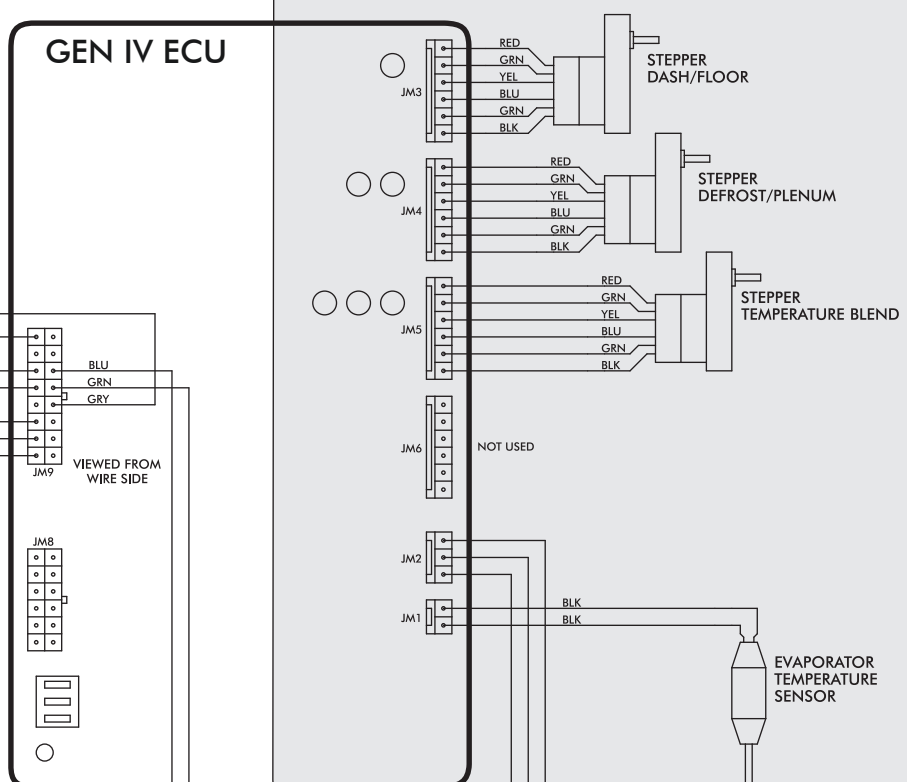

PRE-WIRED

NOTE: = CHASSIS GROUND

- \* Dash lamp is used only with type 232007-VUR harness.
- \*\* Warning: Always mount circuit breaker as close to the battery as possible. (NOTE: Wire between battery and circuit breaker is unprotected and should be carefully routed to avoid a short circuit).
- \*\*\* Wide open throttle switch contacts close only at full throttle, which disables A/C



www.vintageair.com

# Gen IV Wiring Connection Instruction

WIRING HARNESS

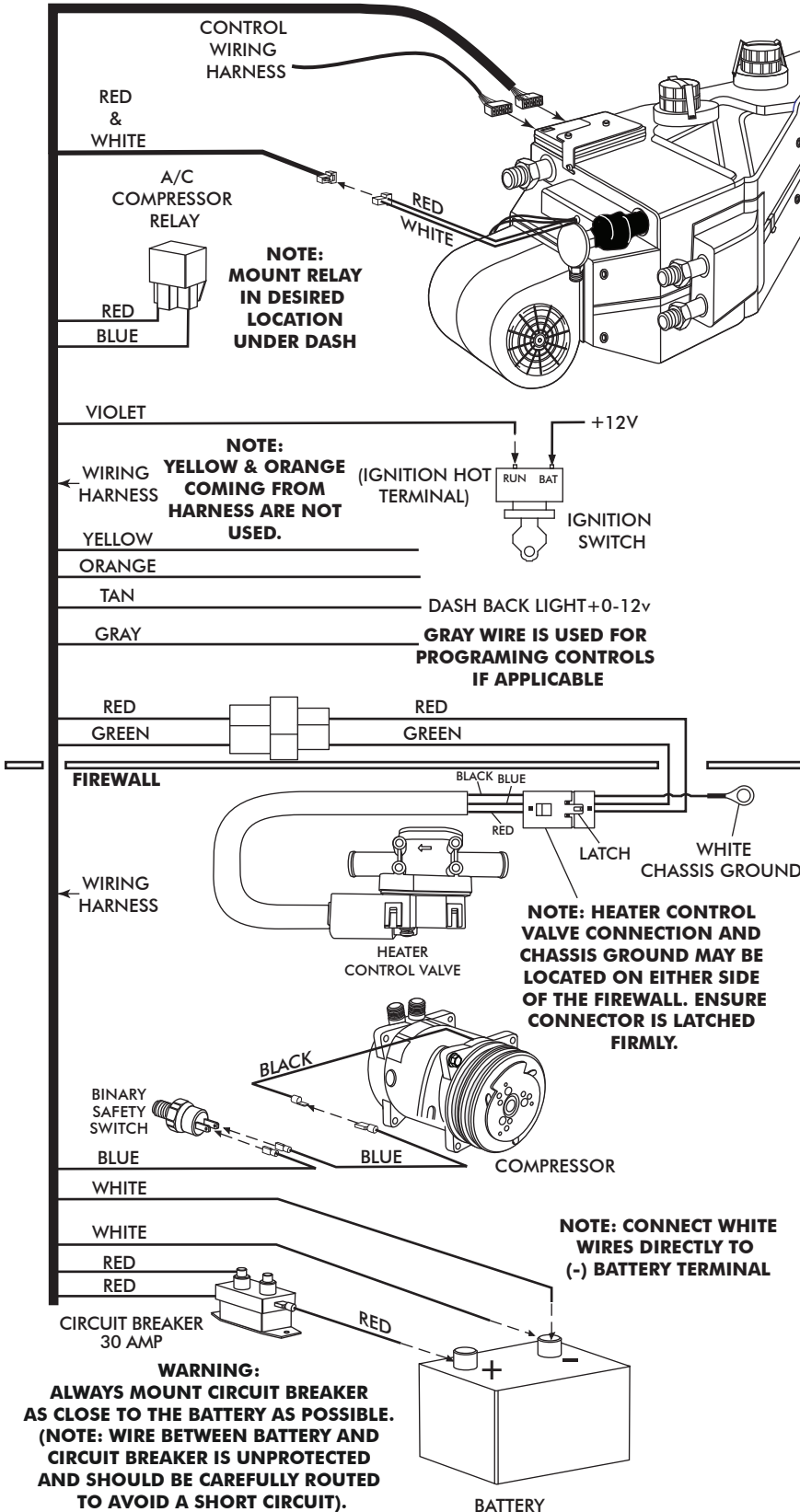

### Ignition Switch:

Violet 12V ignition switch source (key on accessory) position must be switched.

### Dash Light:

When using a Vintage Air-supplied control panel, connect the tan wire from the Gen IV evaporator wiring harness to the factory dash lights to enable panel backlighting.

### Heater Control Valve:

Install with servo motor facing down, as shown. Note flow direction arrow molded into valve body and install accordingly.

### Binary/Trinary & Compressor:

Binary: Connect as shown (typical compressor wiring). Be sure compressor body is grounded.

Trinary Switch: Connect according to trinary switch wiring diagram.

### Circuit Breaker/Battery:

White **must** run to (-) battery. Red may run to (+) battery or starter. Mount circuit breaker as close to battery as possible.



www.vintageair.com

## Operation of Controls

On Gen IV systems with three lever/knob controls, the temperature control toggles between heat and A/C operations. To activate A/C, move the temperature lever/knob all the way to cold and then back it off to the desired vent temperature. For heat operation, move the temperature lever/knob all the way to hot and then adjust to the desired vent temperature. The blower will momentarily change speed, each time you toggle between operations, to indicate the change. **NOTE: For proper control panel function, refer to the control panel instructions for calibration procedure.**

### Blower Speed

This lever/knob controls blower speed, from OFF to HI.

### Mode Control

This lever/knob controls the mode positions, from DASH to FLOOR to DEFROST, with a blend in between.

### Temperature Control

This lever/knob controls the temperature, from HOT to COLD.

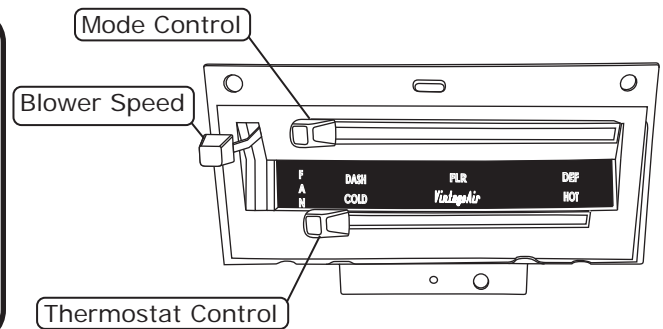

## A/C Operation

### Blower Speed

Adjust to desired speed.

### Mode Control

Adjust to desired mode position (DASH position recommended).

### Temperature Control

For A/C operation, adjust to coldest position to engage compressor (Adjust between HOT and COLD to reach desired temperature).

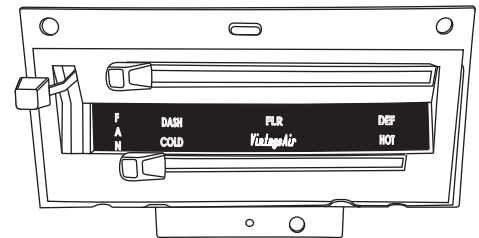

## Heat Operation

### Blower Speed

Adjust to desired speed.

### Mode Control

Adjust to desired mode position (FLOOR position recommended).

### Temperature Control

For maximum heating, adjust to hottest position (Adjust between HOT and COLD to reach desired temperature).

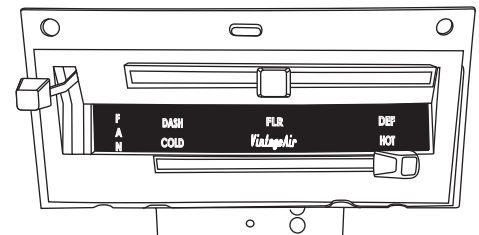

## Defrost/De-fog Operation

### Blower Speed

Adjust to desired speed.

### Temperature Control

Adjust to desired temperature.

### Mode Control

Adjust to DEFROST position for maximum defrost, or between FLOOR and DEFROST positions for a bi-level blend (Compressor is automatically engaged).

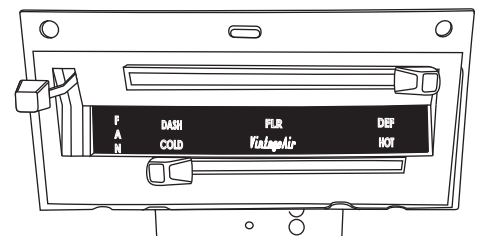



www.vintageair.com

# Troubleshooting Guide

| Symptom  | Condition                 | Checks  | Actions  | Notes   |
|--|---------------------------|---|--|---|
| 1a.<br>Blower stays on high speed when ignition is on.         | No other functions work.  | Check for damaged pins or wires in control head plug.   | Verify that all pins are inserted into plug. Ensure that no pins are bent or damaged in ECU.   | Loss of ground on this wire renders control head inoperable.  |
|  |                           | Check for damaged ground wire (white) in control head harness.  | Verify continuity to chassis ground with white control head wire at various points.  |   |
|  | All other functions work. | Check for damaged blower switch or potentiometer and associated wiring.   |  | See blower switch check procedure.  |
|  |                           |   |  |   |
| 1b.<br>Blower stays on high speed when ignition is on or off.  |                           | Unplug 3-wire BSC control connector from ECU. If blower shuts off, ECU is either improperly wired or damaged.     | Be sure the small, 20 GA white ground wire is connected to the battery ground post. If it is, replace the ECU.   | No other part replacements should be necessary.   |
|  |                           | Unplug 3-wire BSC control connector from ECU. If blower stays running, BSC is either improperly wired or damaged. | Check to ensure that no BSC wiring is damaged or shorted to vehicle ground. The BSC operates the blower by ground side pulse width modulation switching. The positive wire to the blower will always be hot. If the "ground" side of the blower is shorted to chassis ground, the blower will run on HI. |   |
|  |                           | Replace BSC (This will require removal of evaporator from vehicle).   |  |   |
|  |                           |   |  |   |
| 2.<br>Compressor will not turn on (All other functions work).  | System is not charged.    | System must be charged for compressor to engage.  | Charge system or bypass pressure switch.   | <b>Danger: Never bypass safety switch with engine running. Serious injury can result.</b>   |
|  |                           | Check for faulty A/C potentiometer or associated wiring (not applicable to 3-pot controls).                       | Check continuity to ground on white control head wire. Check for 5V on red control head wire.  |   |
|  | System is charged.        | Check for disconnected or faulty thermistor.  | Check 2-pin connector at ECU housing.  | To check for proper pot function, check voltage at white/blue wire. Voltage should be between 0V and 5V, and will vary with pot lever position.   |
|  |                           |   |  | Disconnected or faulty thermistor will cause compressor to be disabled.   |
|  |                           |   |  | Red wire at A/C pot should have approximately 5V with ignition on. White wire will have continuity to chassis ground. White/Blue wire should vary between 0V and 5V when lever is moved up or down. |
| 3.<br>Compressor will not turn off (All other functions work). |                           | Check for faulty A/C potentiometer or associated wiring.  | Repair or replace pot/control wiring.  |   |
|  |                           | Check for faulty A/C relay.   | Replace relay.   |   |



www.vintageair.com

# Troubleshooting Guide (Cont.)

| Symptom | Condition  | Checks   | Actions   | Notes  |
|---------|--|--|---|--|
| 4.      | Works when engine is not running; shuts off when engine is started (typically early Gen IV, but possible on all versions).       | Noise interference from either ignition or alternator.   | Install capacitors on ignition coil and alternator. Ensure good ground at all points. Relocate coil and associated wiring away from ECU and ECU wiring. Check for burned or loose plug wires. | Ignition noise (radiated or conducted) will cause the system to shut down due to high voltage spikes. If this is suspected, check with a quality oscilloscope. Spikes greater than 16V will shut down the ECU. Install a radio capacitor at the positive post of the ignition coil (see radio capacitor installation bulletin). A faulty alternator or worn out battery can also result in this condition. |
|         | System will not turn on, or runs intermittently.   | Will not turn on under any conditions.   | Check for positive power at heater valve green wire and blower red wire. Check for ground on control head white wire.   |  |
|         |  | Verify battery voltage is greater than 10 volts and less than 16.  | Verify proper meter function by checking the condition of a known good battery.   |  |
| 5.      | No mode change at all.   | Check for damaged mode switch or potentiometer and associated wiring.  |   | Typically caused by evaporator housing installed in a bind in the vehicle. Be sure all mounting locations line up and don't have to be forced into position.   |
|         | Partial function of mode doors.  | Check for obstructed or binding mode doors.  |   |  |
|         |  | Check for damaged stepper motor or wiring.   |   |  |
| 6.      | Battery voltage is at least 12V.   | Check for at least 12V at circuit breaker.   | Ensure all system grounds and power connections are clean and tight.  | System shuts off blower at 10V. Poor connections or weak battery can cause shutdown at up to 11V.  |
|         | Blower turns on and off rapidly.   | Battery voltage is less than 12V.  | Charge battery.   |  |
| 7.      | Erratic functions of blower, mode, temp, etc.  | Check for damaged switch or pot and associated wiring.   | Repair or replace.  |  |
| 8.      | When ignition is turned on, blower momentarily comes on, then shuts off. This occurs with the blower switch in the OFF position. | This is an indicator that the system has been reset. Be sure the red power wire is on the battery post, and not on a switched source. Also, if the system is pulled below 7V for even a split second, the system will reset. | Run red power wire directly to battery.   |  |





www.vintageair.com

# Driver Side Louver Template

NOTE: Due to printing variances, measure the line below before using this template. If template is scaled properly, the line should measure 6 inches.

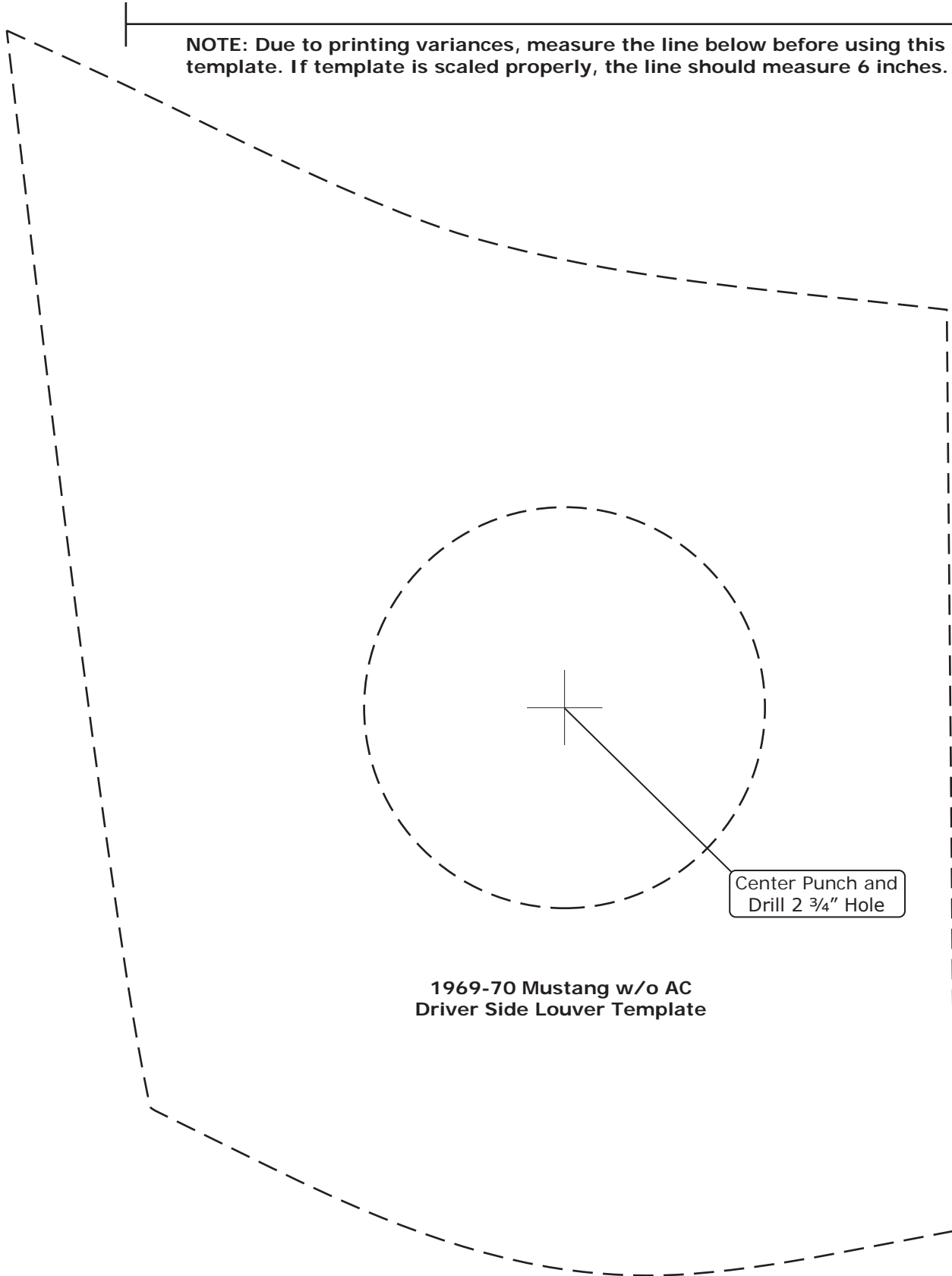

1969-70 Mustang w/o AC  
Driver Side Louver Template





# Passenger Side Louver Template

NOTE: Due to printing variances, measure the line below before using this template. If template is scaled properly, the line should measure 6 inches.

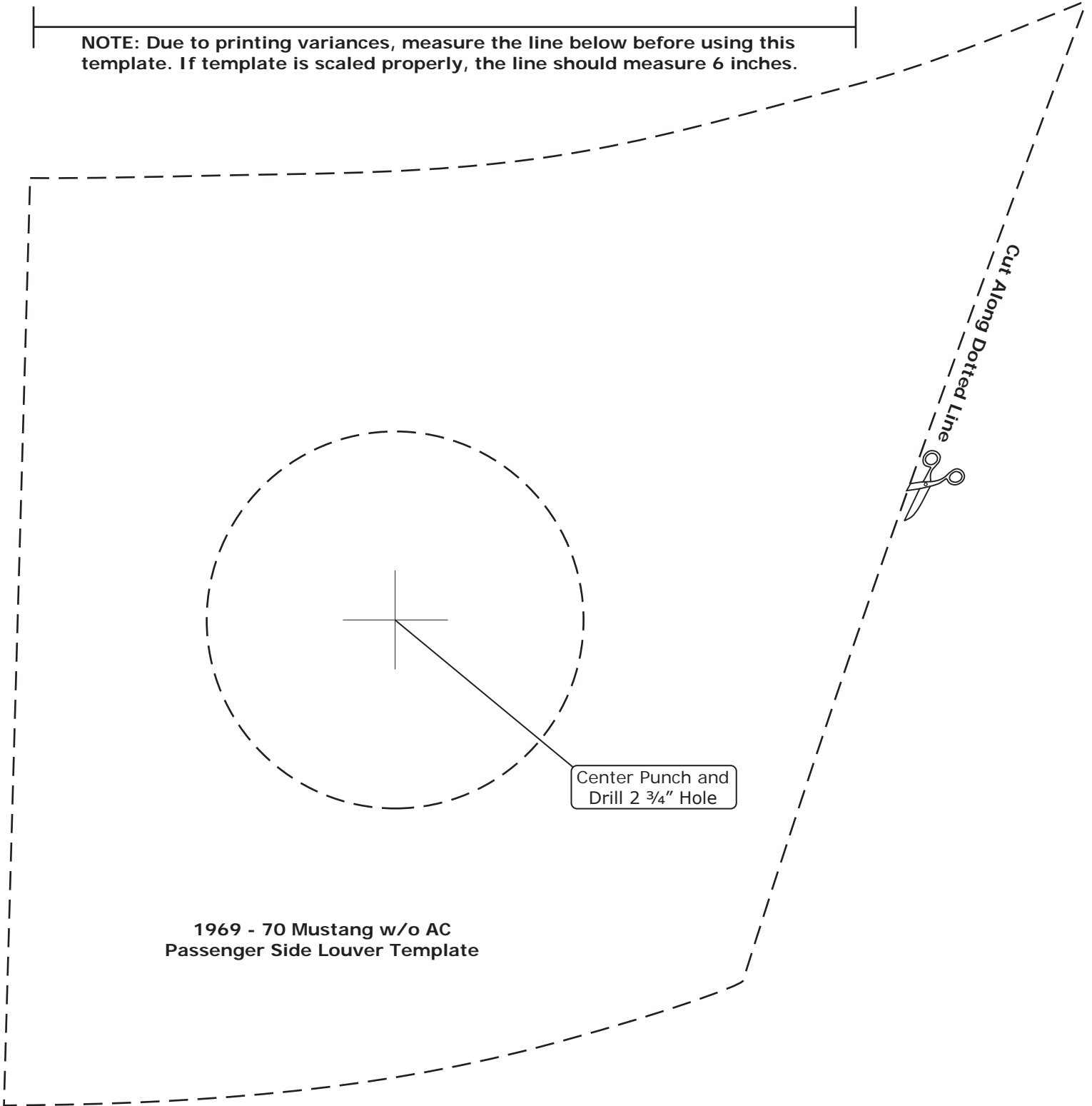

1969 - 70 Mustang w/o AC  
Passenger Side Louver Template





www.vintageair.com

# Center Louver Template

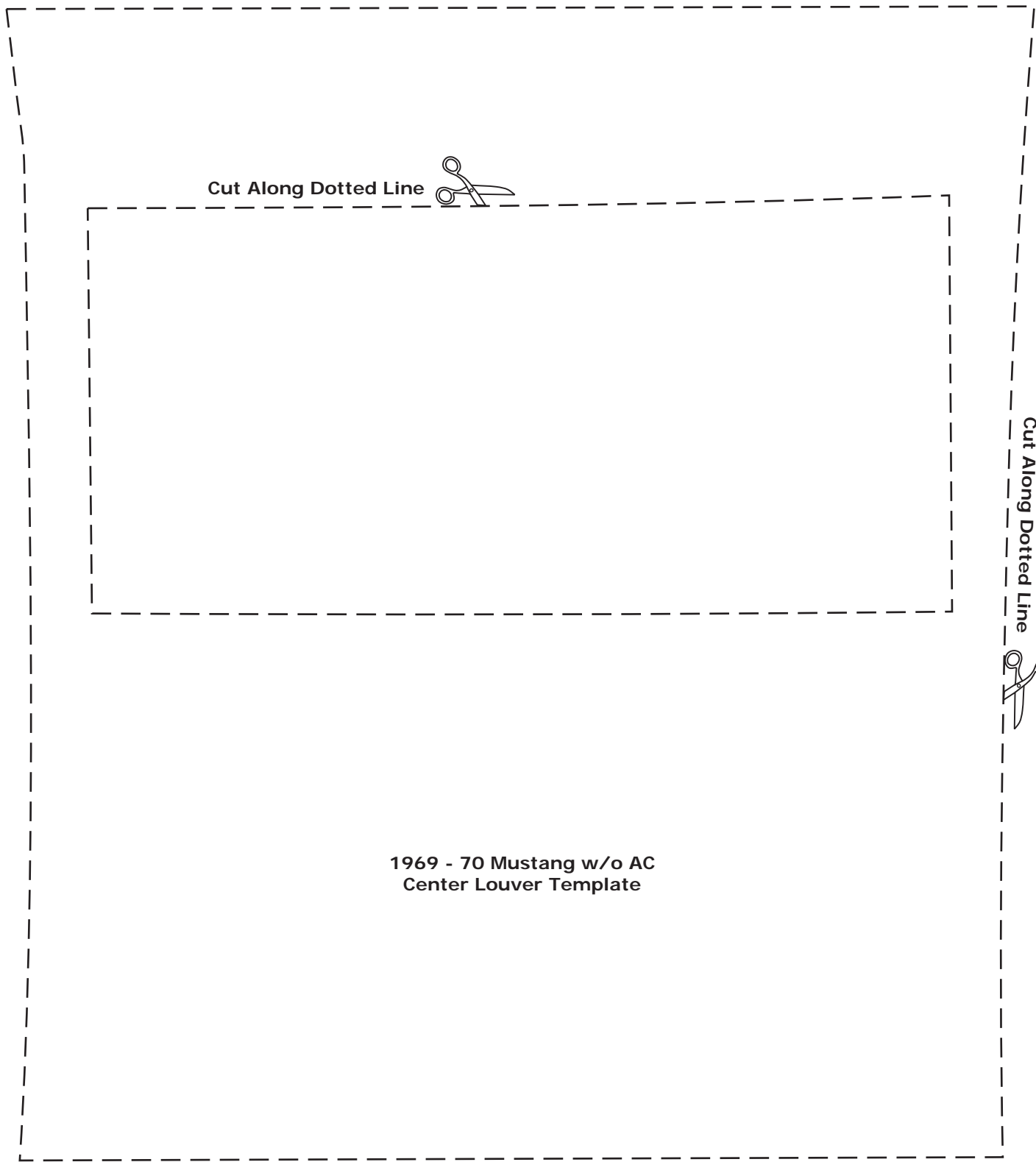

1969 - 70 Mustang w/o AC  
Center Louver Template

NOTE: Due to printing variances, measure the line below before using this template. If template is scaled properly, the line should measure 6 inches.



1969 - 70 Mustang w/o AC  
Firewall Cover Hole Template

(6) 3/16" Holes

OEM Heater Hole

Blower Motor Mounting Hole

Blower Motor Mounting Hole

Cut Along Dotted Line

(4) Alignment Holes

Blower Motor mounting Hole

Blower Motor Mounting Hole

Cut Along Dotted Line







www.vintageair.com

## Packing List: Evaporator Kit (551170)

| No. | Qty. | Part No.   | Description                       |
|-----|------|------------|-----------------------------------|
| 1.  | 1    | 744004-VUE | Gen IV 4-Vent Evaporator Sub Case |
| 2.  | 1    | 781069     | Accessory Kit                     |

Checked By: \_\_\_\_\_  
Packed By: \_\_\_\_\_  
Date: \_\_\_\_\_

1

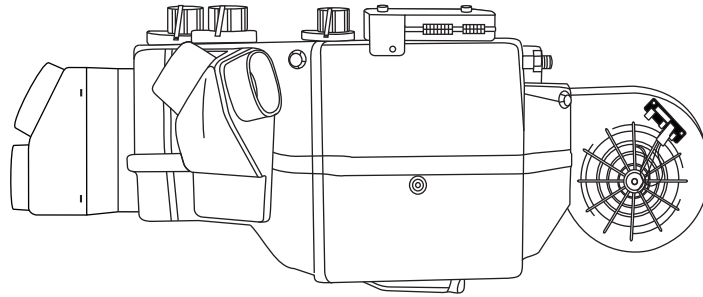

**Gen IV 4-Vent Evaporator  
Sub Case  
744004-VUE**

2

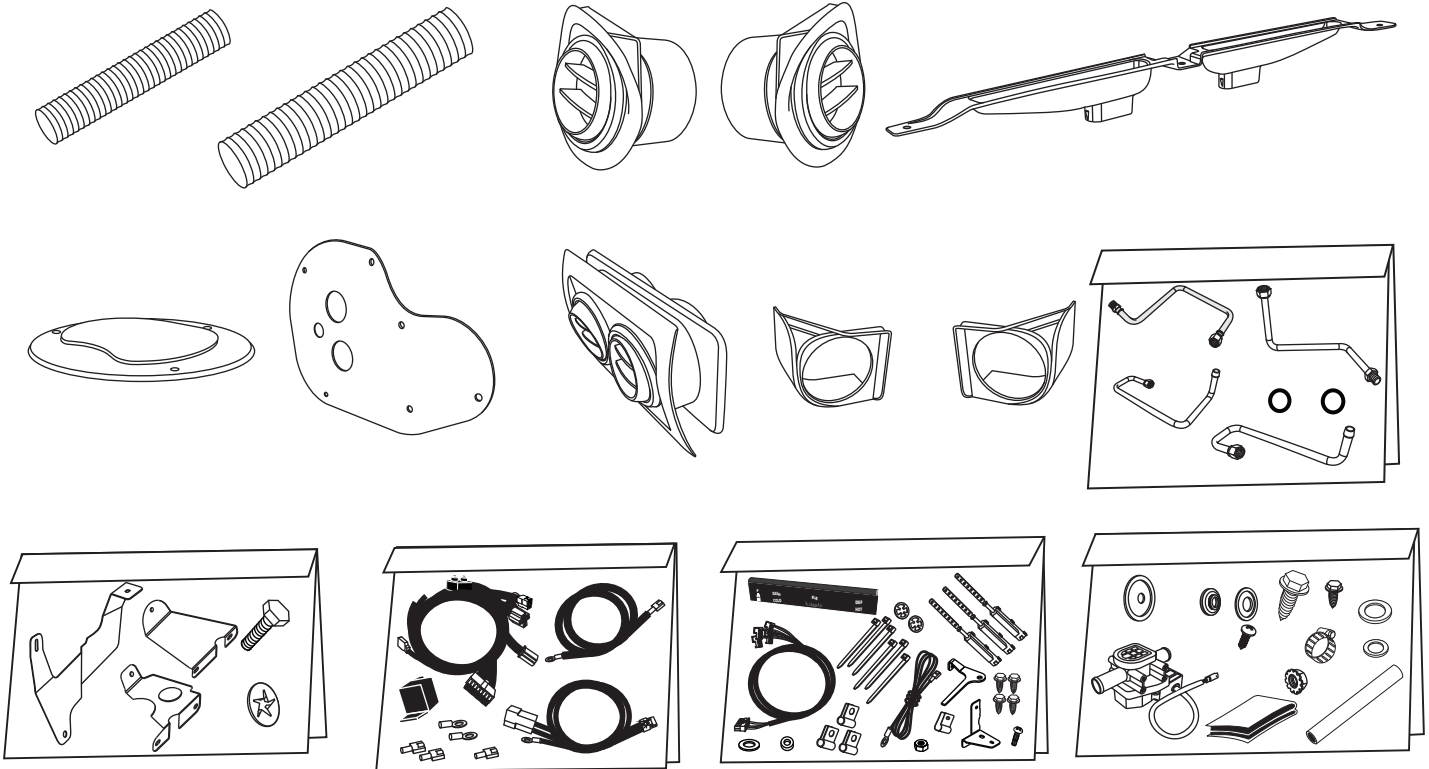

**Accessory Kit  
781069**

**NOTE: Images may not depict actual parts and quantities.  
Refer to packing list for actual parts and quantities.**